

Product Overview SLH239

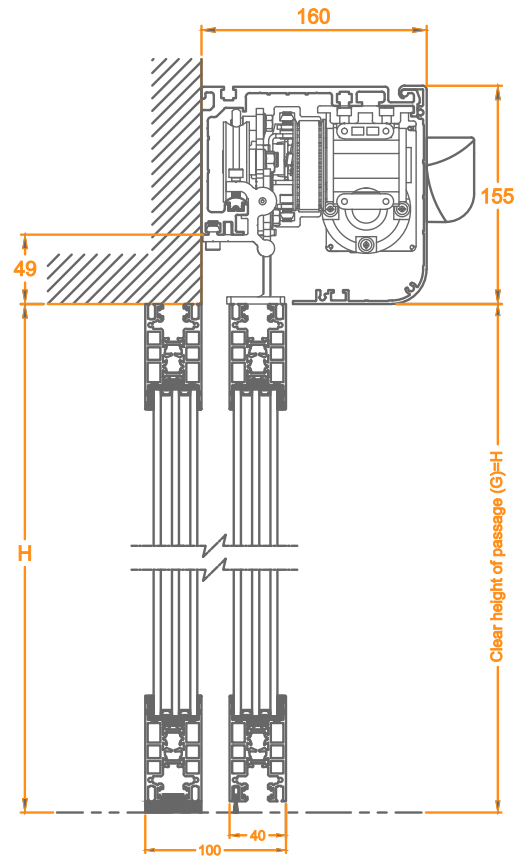

	SLH239
compliant with german standard DIN 18650	✓
compliant with EU standard EN 16005	✓
compliant with EU standard EN 60335	✓
compliant with EU standard EN ISO 13849-1:2008	✓
compliant with EU low-voltage directives	✓
compliant with EU EMC directives	✓
manufactured according to ISO 9001:2000	✓
TÜV approved	✓
CE conformity	✓
tested for 1.000.000 cycles	✓

SLH239

opening width - single panel	800 - 2000mm
opening width - double panel	1000 - 3000mm
max leaf weight, single	150kg
max leaf weight, double	2 x 100kg
operator height	155mm
operator depth	160mm
opening speed	100 - 550mm/s
closing speed	100 - 500mm/s
hold-open time	0 - 30s
ambient temperature	-15 to +50°C
protection class	IP20
100% german-made operator kit	✓
track profile	anti-crash stainless steel
anti-noise rubber profile	✓
external protected power supply	✓
input power	230V AC ±10%, 50/60Hz
gear motor power	50W
maximum power consumption	200W
maximum operation cycles with 2.2 Ah backup battery <small>(optional)</small>	450
maximum operation cycles with 7.2 Ah backup battery <small>(optional)</small>	1100

SLH239

possibility to use safety sensors with testing signal	✓
possibility to adjust force limitation according to DIN 18650 and EN 16005	✓
mechanical key switch	✓
24V DC output for external accessories	✓
power lock	✓
possibility of using electro-mechanical lock <small>(optional)</small>	✓
lock monitoring	✓
possibility of using highly secure electromechanical multi-point lock <small>(HSML)</small>	✓
possibility of using digital programme switch <small>(optional)</small>	✓
read-out error memory with error codes <small>(with digital programme switch)</small>	✓
programmable output <small>(optional)</small>	✓
programmable input <small>(optional)</small>	✓
possibility of using more software and hardware options by using DEAP device <small>(optional)</small>	✓

Variants:	SLH239
V-Shape door	✓
Curved door	✓
Break out	✓
Telescopic door	✓
FrameTypes:	
THB	✓
TBS	✓
UTS	✓
Saturn	✓
Frameless	✓

